

CAPS NO₂ MONITOR

*Accurate and Precise
Continuous Monitoring of
Ambient Nitrogen Dioxide.*



APPLICATIONS:

- Visible (450 nm) absorption measurement using patented Cavity Attenuated Phase Shift (CAPS) technology.
- Measurement of ambient concentrations to 3000 ppbv.
- Stack Gas Monitoring.
- Medical Inhalant Purity Monitoring.
- Combustion Plume Analysis (Fast Response [1 s] Version).
- LOD (3 σ , 10 s) = <0.1 ppb.

ADVANTAGES:

- Direct measurement of analyte - no chemical conversion required.
- Insensitive to presence of varying levels of nitric oxide, aerosols, humidity and other trace atmospheric species.
- Essentially interference-free.
- Linear Response (0-3000 ppbv).
- Minimal maintenance (periodic change of particle filter).
- No Toxic Gas Emissions.

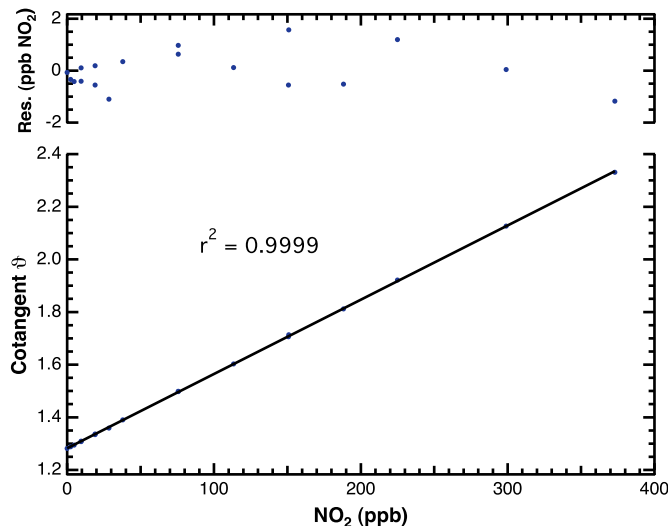

Observed linearity of CAPS monitor signal as a function of NO₂ concentration from zero to ~ 400 ppbv.

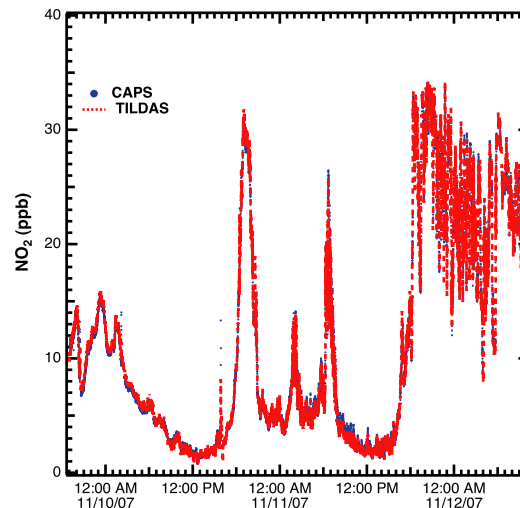

Comparison of data taken with CAPS-based NO₂ and quantum cascade laser-based (TILDAS) monitors during field study.

CAPS NO₂ MONITOR

SPECIFICATIONS:

Sensitivity (S/N =3)	Ambient Monitoring: < 0.1 ppb (10 s) Fast Response Version: < 1.5 ppb (1 s) (No Dryer)
Response Time (10-90%)	Ambient Monitoring: 8 s Fast Response Monitor: 1 s
Sample Flow	0.85 l min ⁻¹ ambient monitor 4.5 l min ⁻¹ fast response monitor
Operating Pressure	Ambient
Materials Exposed to Analyte:	Stainless Steel, PFA and Nafion
Data Output:	RS-232 (Data acquisition and instrument control software provided) On-Board Data Storage (800 MB)– Download through USB Port Front Panel Display
Size/Weight:	Rack mount, 19" x 24" x 9.06", 25 lbs. [61 cm x 43 cm x 23 cm, 12 kg]
Electric Power:	100 W; 100-250 VAC (50-60 Hz)

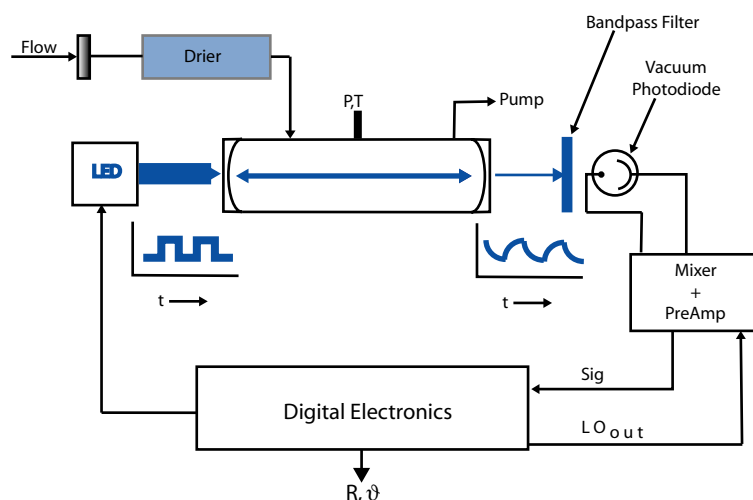

REFERENCES

"A Practical Alternative to Chemiluminescence Detection of Nitrogen Dioxide: Cavity Attenuated Phase Shift Spectroscopy, P.L. Keabian, E.C. Wood, S.C. Herndon, and A. Freedman, Environ. Sci. Technol., 42:6040-6045 (2008).

"System and method for trace species detection using cavity attenuated phase shift spectroscopy with an incoherent light source", P.L. Keabian and A. Freedman, U.S. Patent No. 7301639 (issued November 27, 2007).

"Detection of Nitrogen Dioxide by Cavity Attenuated Phase Shift Spectroscopy", Paul L. Keabian, Scott C. Herndon and Andrew Freedman, Anal. Chem., 77:724-728 (2005).